

Piezoelectric Vibrating Gyroscopes (GYROSTAR®)



Piezoelectric Vibrating Gyroscopes (GYROSTAR®)

This product is an angular velocity sensor that uses the phenomenon of Coriolis force, which is generated when a rotational angular velocity is applied to the vibrator.

Murata's original small ceramic bimorph vibrator and simple Cap-Base structure achieve an ultra-small size of about 0.2cc. Their small and lightweight shape increase flexibility of installment and help your apparatuses to be downsized.

These surface-mountable devices can be mounted by automatic surface mounters.

■ Features

1. Ultra-small and ultra-lightweight
2. Quick response
3. Low driving voltage, low current consumption
4. Lead type : SMD
5. Reflow soldering (standard peek temp. 245 degree C)

■ Applications

1. Detecting hand movement involved in video and still cameras
2. Detecting vibrations in various vibration-free tables and isolators
3. Detecting various movements comprising rotation

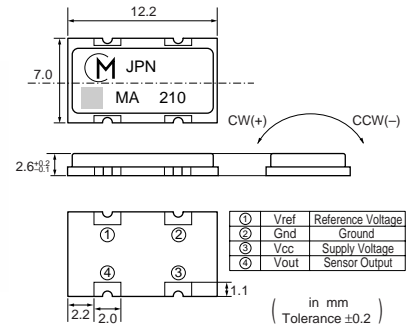

Part Number	Supply Voltage (Vdc)	Maximum Angular Velocity (deg./sec.)	Output (at Angular Velocity=0) (Vdc)	Scale Factor (mV/deg./sec.)	Linearity (%FS)	Response (Hz)	Weight (g)
ENC-03M	2.7~5.25	+/-300	1.35	0.67	+/-5	50 max.	0.4

Operating Temperature Range : -5°C to 75°C Storage Temp. Range : -30°C to 85°C

■ Sample Amplifier Circuit

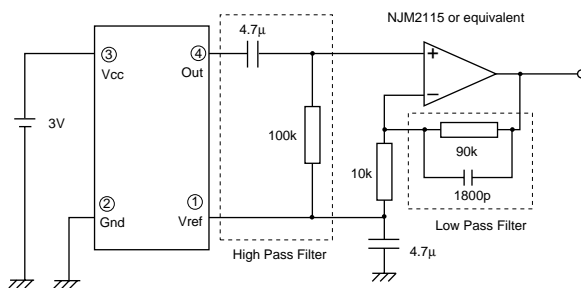

The High-pass Filter's Cut-off frequency in this circuit is approx. 0.3Hz.
The Low-pass Filter's Cut-off frequency in this circuit is approx. 1kHz.

Application/Packaging

■ Application

1. One sensor detects rotation on one axis. If two axes are to be detected in the same equipment, two different types of sensors (EMC-03MA and EMC-03MB) should be used.
2. To reduce the effect of temperature drift (due to change of ambient temperature), a high pass filter must be connected to sensor output to eliminate DC component.
3. To suppress output noise component around 22-25kHz (resonant frequency of sensor element), a low pass filter which has higher cut-off frequency than required response frequency must be connected to sensor output.

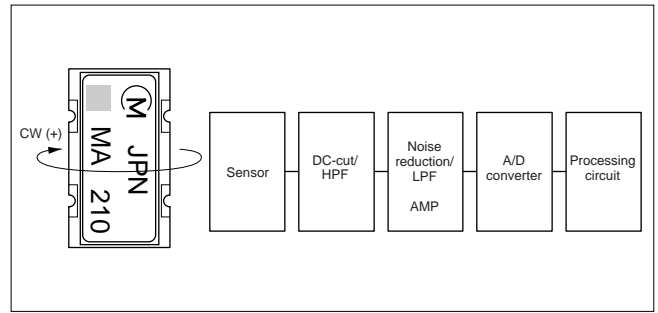

■ Dimensions of Land Pattern

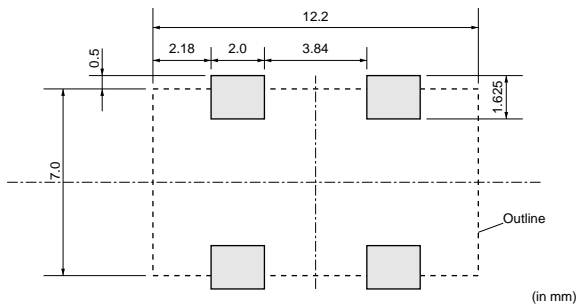

■ Dimensions of Reel

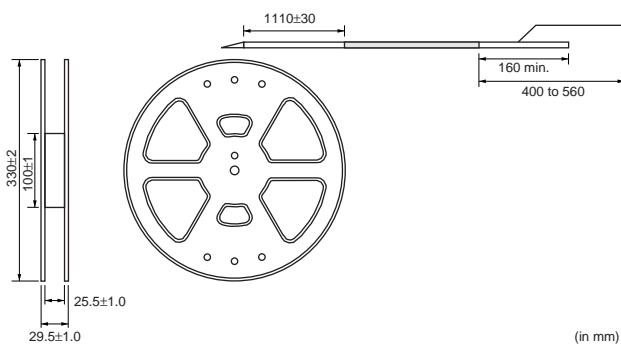

■ Dimensions of Plastic Tape

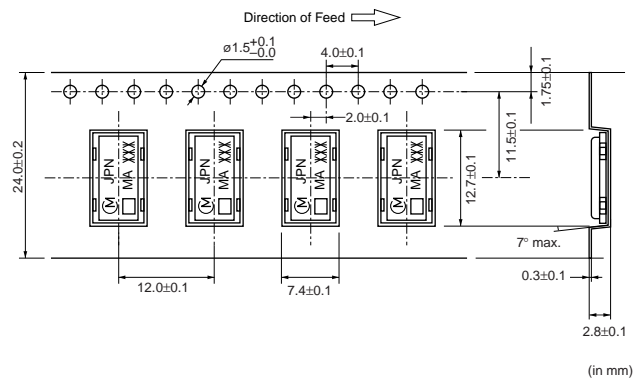

Notice

■ Notice (Storage and Operating Conditions)

1. Do not install the sensor in a location in which condensation is likely to form on it.
2. This sensor must be installed where temperature does not vary significantly.
3. Do not use under excessively shocked or vibrated conditions.

■ Notice (Soldering and Mounting)

This sensor must be installed in the correct position relative to the direction of rotation to be detected.

■ Notice (Handling)

1. Incorrect handling may affect sensor characteristics. Please note the following precautions:
 - (1) Do not subject the sensor to shock that exceeds the rated limit.
 - (2) Do not wash the sensor.
2. Precision electronic parts, such as ICs, are used for the sensor; therefore, it is necessary to take anti-static measures when handling.

● Part Numbering (The structure of the "Global Part Numbers" that have been adopted since June 2001 and the meaning of each code are described herein.) If you have any questions about details, inquire at your usual Murata sales office or distributor.

Piezoelectric Gyroscopes (GYROSTAR®)

(Global Part Number)

EN	C-03MA	-02	
①	②	③	④

① Product ID

② Type

③ Individual Specification Code

④ Packaging

* Global Part Number shows only an example which might be different from actual part number.

* Any other definitions than "① Product ID" might have a different digit number from actual Global Part Number.

⚠Note:

1. Export Control

⟨For customers outside Japan⟩

Murata products should not be used or sold for use in the development, production, stockpiling or utilization of any conventional weapons or mass-destructive weapons (nuclear weapons, chemical or biological weapons, or missiles), or any other weapons.

⟨For customers in Japan⟩

For products which are controlled items subject to the "Foreign Exchange and Foreign Trade Law" of Japan, the export license specified by the law is required for export.

2. Please contact our sales representatives or product engineers before using the products in this catalog for the applications listed below, which require especially high reliability for the prevention of defects which might directly damage to a third party's life, body or property, or when one of our products is intended for use in applications other than those specified in this catalog.

- | | |
|-----------------------------|-------------------------------------------------------------------------------------------------------------|
| ① Aircraft equipment | ② Aerospace equipment |
| ③ Undersea equipment | ④ Power plant equipment |
| ⑤ Medical equipment | ⑥ Transportation equipment (vehicles, trains, ships, etc.) |
| ⑦ Traffic signal equipment | ⑧ Disaster prevention / crime prevention equipment |
| ⑨ Data-processing equipment | ⑩ Application of similar complexity and/or reliability requirements to the applications listed in the above |

3. Product specifications in this catalog are as of November 2002. They are subject to change or our products in it may be discontinued without advance notice. Please check with our sales representatives or product engineers before ordering. If there are any questions, please contact our sales representatives or product engineers.

4. Please read rating and ⚠CAUTION (for storage, operating, rating, soldering, mounting and handling) in this catalog to prevent smoking and/or burning, etc.

5. This catalog has only typical specifications because there is no space for detailed specifications. Therefore, please approve our product specifications or transact the approval sheet for product specifications before ordering.

6. Please note that unless otherwise specified, we shall assume no responsibility whatsoever for any conflict or dispute that may occur in connection with the effect of our and/or a third party's intellectual property rights and other related rights in consideration of your use of our products and/or information described or contained in our catalogs. In this connection, no representation shall be made to the effect that any third parties are authorized to use the rights mentioned above under licenses without our consent.

7. No ozone depleting substances (ODS) under the Montreal Protocol are used in our manufacturing process.